***BlockMaster/SignalMaster* Application Note #5**

Interfacing with the Digitrax BDL16/BDL162

The Digitrax BDL16 provides train detection of 16 blocks along with LocoNet® communication. Although our ***BlockMaster*** and ***SignalMaster*** boards also provide train detection it is possible to use these products together with our products providing the signaling logic. This application note illustrates how to use the BDL16's block occupancy outputs to trigger the block detection circuitry on either the ***BlockMaster*** or ***SignalMaster***.

The key component used to "bridge" these products is an opto-isolator. Figure 1 shows a typical opto-isolator such as the 4N35. The opto-isolator consists of an infrared LED and a phototransistor. When the LED is turned on it emits light (internal to the package) which is sensed by the phototransistor and causes it to turn and conduct current.

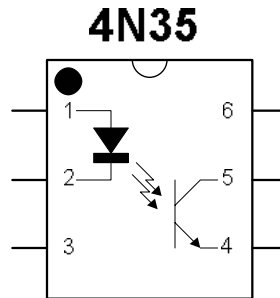

Figure 1 – 4N35 opto-isolator

In this application you will need one 4N35 for each block that needs to be interfaced to a ***BlockMaster*** or ***SignalMaster***. The BDL16 has a block occupancy output for each of the 16 blocks that it detects. A block occupancy output will be used to control the LED portion of the 4N35. The phototransistor portion of the 4N35 will be used to stimulate a block detection input on the ***BlockMaster/SignalMaster***. For each block you will need:

- One 4N35 opto-isolator
- One 10K ohm, 1/4W resistor
- One "detection diode" (Two are provided with the ***BlockMaster/SignalMaster*** for each block)
- Connector and wire/cable for the BDL16's External LED connectors (refer to the BDL16 manual for more information); one connector covers four blocks

Figure 2 shows the interface wiring for one detection block (refer to the BDL16 manual for track wiring, etc). **NOTE: You MUST use separate power sources for the BDL16 and the BlockMaster/SignalMaster. You can share power sources between multiple BlockMaster/SignalMaster boards or must at least establish a common ground between those boards; all of this is described in the manual for those products.**

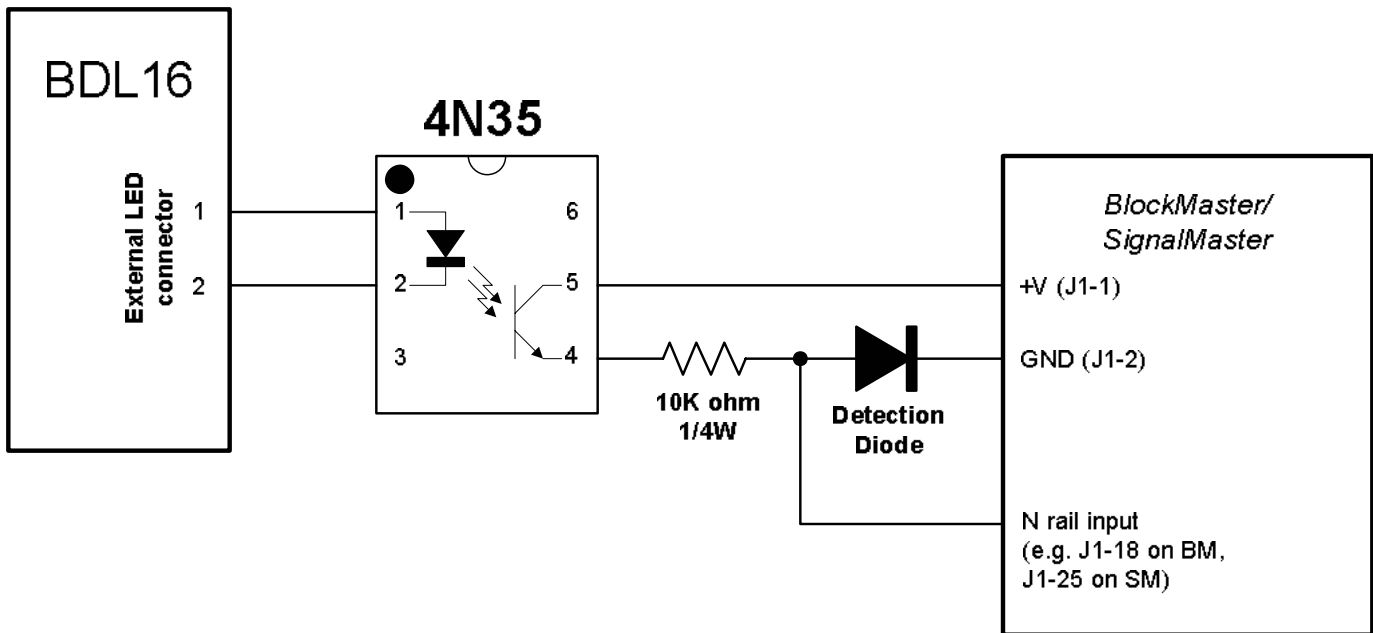
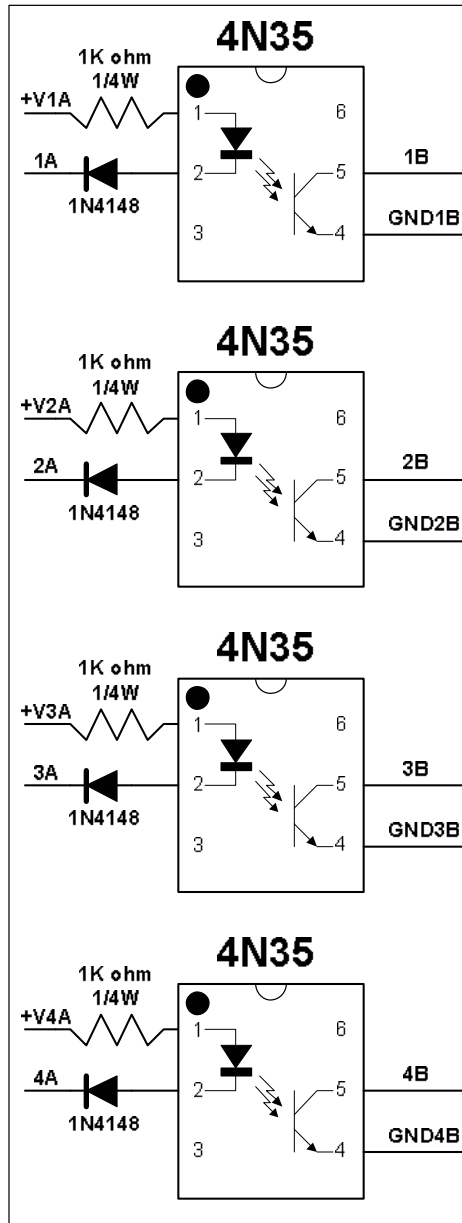

Figure 2 – BDL16 to BlockMaster/SignalMaster interface

When the BDL16 detects a block as occupied it will turn on the LED portion of the 4N35. That will turn on the 4N35's phototransistor. When the phototransistor is on it will allow current to flow from the +V of the BlockMaster/SignalMaster through the 10K ohm resistor and then through the detection diode and back to the GND of the BlockMaster/SignalMaster. The BlockMaster/SignalMaster senses the current flowing through the detection diode, via its N rail input, and thus determines the block to be occupied. When the BDL16 senses an empty block then the LED will be off and thus no current will be flowing through the other portion of the circuit and the BlockMaster/SignalMaster will determine the block to be empty.

If you still wish to have block occupancy panel indicators you can use the block occupied outputs from the BlockMaster/SignalMaster. Refer to the appropriate product manual for more details.

We offer a printed circuit board (#OPTO4) that consists of four independent 4N35 circuits. The schematic diagram for the board is shown in below. For this application the 1K resistor and the 1N4148 diode aren't used; you will replace these components with wire jumpers. The OPTO4 is sold in kit form; contact us for pricing and ordering.



We also offer a pre-wired printed circuit board (#OPTO4BDL) that consists of four independent 4N35 circuits as well as the proper cable and connector to mate to the BDL16/BDL162. You'll need two OPTO4BDL boards per *SignalMaster*; one OPTO4BDL board will cover two *BlockMasters*. The board is illustrated below. Please note that although the 10K ohm resistors are provided with this board they are not mounted on the board itself; the detection diodes are included with the *BlockMaster/SignalMaster*. Contact us for OPTO4BDL pricing and ordering.

NOTE: You MUST use separate power sources for the BDL16 and the *BlockMaster/SignalMaster*. You can share power sources between multiple *BlockMaster/SignalMaster* boards or must at least establish a common ground between those boards; all of this is described in the manual for those products.

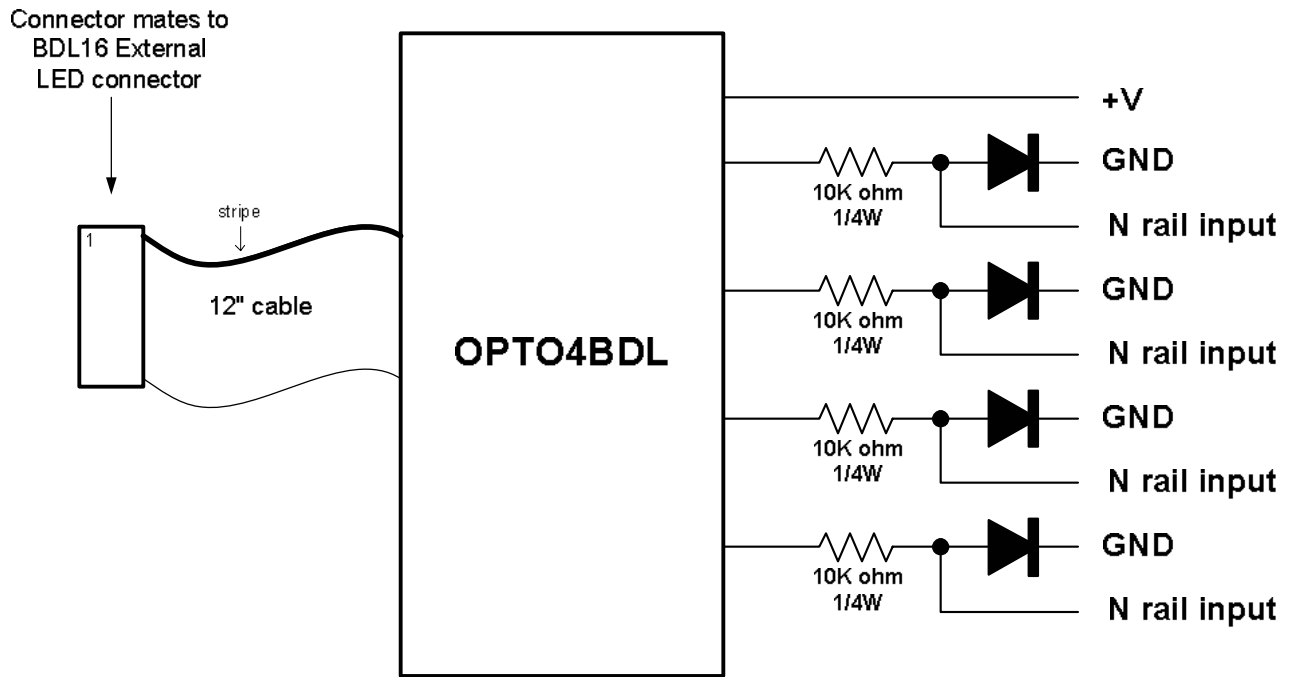

If you have any questions about this application note please contact us via email, fax, or phone.