

Introduction

This application note describes how to use a reflective IR sensor instead of the *Signal Animator's* (SA) optical detection that uses a photocell. You might choose this type of sensor in order to operate in dark conditions. This application note does not provide details on wiring your signal – these details are provided in the SA instructions!

A reflective IR sensor consists of an infrared LED (emitter) and a phototransistor (detector) in one physical plastic package. A common example sensor is the Optek OPB704W which is available from Jameco Electronics (www.jameco.com) and other electronic component distributors. In this application you will also need some inexpensive resistors and transistors which are also available from Jameco, Radio Shack, etc.

The IR sensor is presumably mounted between the rails, level with the tops of the ties, with the sensor surface facing up. Actual location and mounting is NOT covered in this application note and is left up to the modeler's creativity!

Illustrated below is the circuitry to replace the photocell.

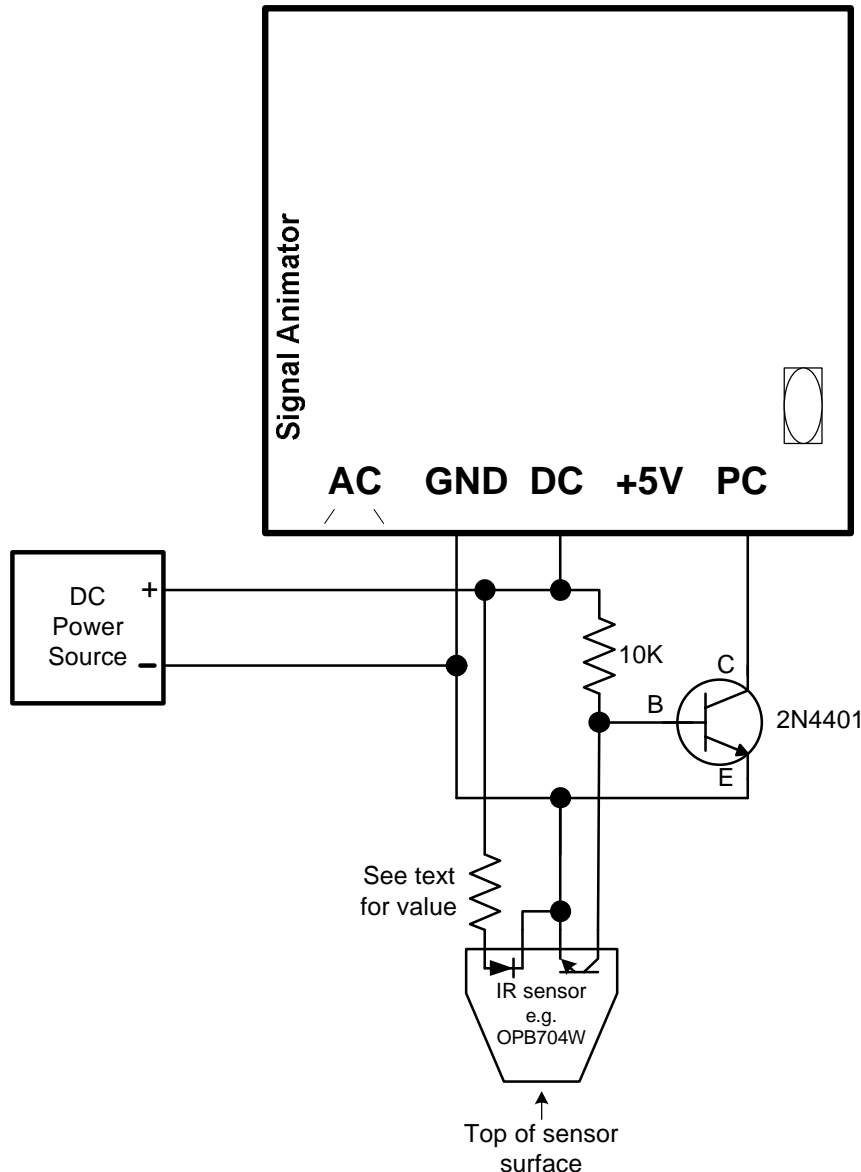

Circuit Operation

The nature of the SA's photocell input is such that a covered photocell (i.e. very high resistance) is detected like an open circuit while an uncovered photocell (i.e. low resistance) is detected as close to 0 volts. The IR sensor's phototransistor is "off" when there is no object present to reflect the IR beam. When an object is present the IR beam will be reflected and the phototransistor will turn "on". As such, the reflective IR sensor provides the opposite of what the SA requires. This is easily "fixed" with the inverter circuit consisting of a 10K ohm resistor (e.g. Radio Shack #271-1335) and an NPN transistor (e.g. Radio Shack #276-2058 or 276-2009). When the IR beam is not reflected by an object the phototransistor will be "off"; as a result the NPN transistor will turn "on" and provide close to 0 volts on the photocell input. When the IR beam is reflected the phototransistor will turn "on" which in turn will turn "off" the NPN transistor; the photocell input will essentially be an open circuit mimicking a covered photocell!

Resistor Value

The IR LED requires a current-limiting resistor. The following table provides recommended values based on the voltage of the DC power source. If you are using a different voltage than one specified in the table then select the resistor value associated with the next highest voltage from the table. We do not recommend DC voltages above 16V. Radio Shack part numbers are provided for your convenience.

DC Power Source	Resistor Value	Radio Shack part number
9V	220 • , ½ Watt	271-1111
12V	330 • , ½ Watt	271-1113
16V	470 • , ½ Watt	271-1115

Photocell sensitivity setup

The SA's photocell sensitivity adjustment potentiometer must be set to the "midway" point. This is easily accomplished by using the procedure detailed below.

1. Insert the blade of a flat-blade screwdriver (from the edge of the circuit board, not from the center of the board) into the adjustment pot. Turn the screwdriver completely **counter-clockwise** in the adjustment pot. Note the position/orientation of the screwdriver.
2. Rotate the potentiometer fully **clockwise** and note the position/orientation of the screwdriver.
3. Now rotate the potentiometer **counter-clockwise** until the screwdriver is approximately half-way between fully clockwise and fully counter-clockwise.

Technical Support

If you need further assistance with this application please do not hesitate to contact us by phone, fax, mail and email; our contact information can be found on the top of Page 1.